



e-bus procurement and roll-out of electric buses

Jeroen Golstein
Provincie Utrecht
eBussed



**Interreg
Europe**



European Union | European Regional Development Fund



Content

- **Project eBussed & Regions**
- **Provincie Utrecht**
 - Utrecht challenges for PT
 - Targets for e-buses
- **Valuechain & Procurement**
- **Charging infrastructure**
- **Other difficulties in transition**
- **Recommendations eBussed**





Main objectives eBussed & partners

- Improving **implementation of public policies** to support regions transitioning towards low-carbon and sustainable electrified public transport
- Improving **exchange of experience** between regions at different stages of e-bus operations
- Increasing capacities of partners, regional policy makers and stakeholders to make informed **decisions** on bus fleet electrification
- Promoting the **uptake** of e-buses in **new regions** and supports the **expansion** of existing e-fleets
- An **action plans** to improve the capacities of partners in e-bus readiness

Provincie Utrecht:



VISIEKAART UTRECHT 2028

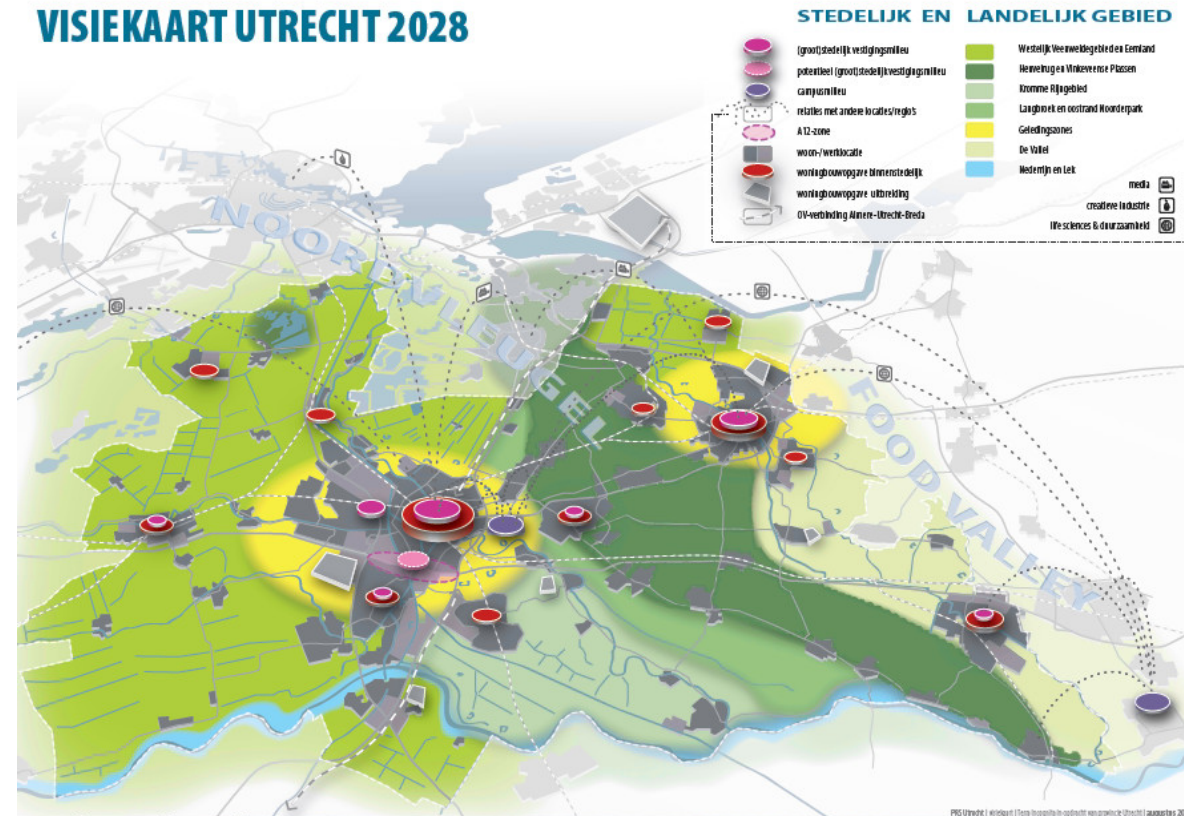

- 1,3 mln inhabitants
- 26 municipality's
- 2 urban area's; densely populated and dynamic economic region
- National/UNESCO-landscape's
- Central Position in the Netherlands:
 - High Mobility-profile (water, rail, road)



Main challenges in Utrecht Region Transport:

- Facilitation growing population in new urban housing project
- Towards Healty Urban Living
- Transition to Carbon free energy
- Transition to sustainable Mobility:
 - **Modal Shift to walking, bike and Public Transport**
 - **From carbon fuel Mobility to Zero Emission vehicles**





Our Target & Schedule

- Provincie of Utrecht aims at **100% zero emission** public transport in 2028:
 - About **520 Zero Emission buses in total**
 - Since 2013 till 2021: 76 e-buses
 - **2022-2024: next 20-40 e-busses**
 - **2025-2028: about 420 Zero Emission buses**
(in Tender new Public Transport Concessions 2025-2035)





Mapping the value chain in eBussed:

Example of the existing situation in Utrecht:

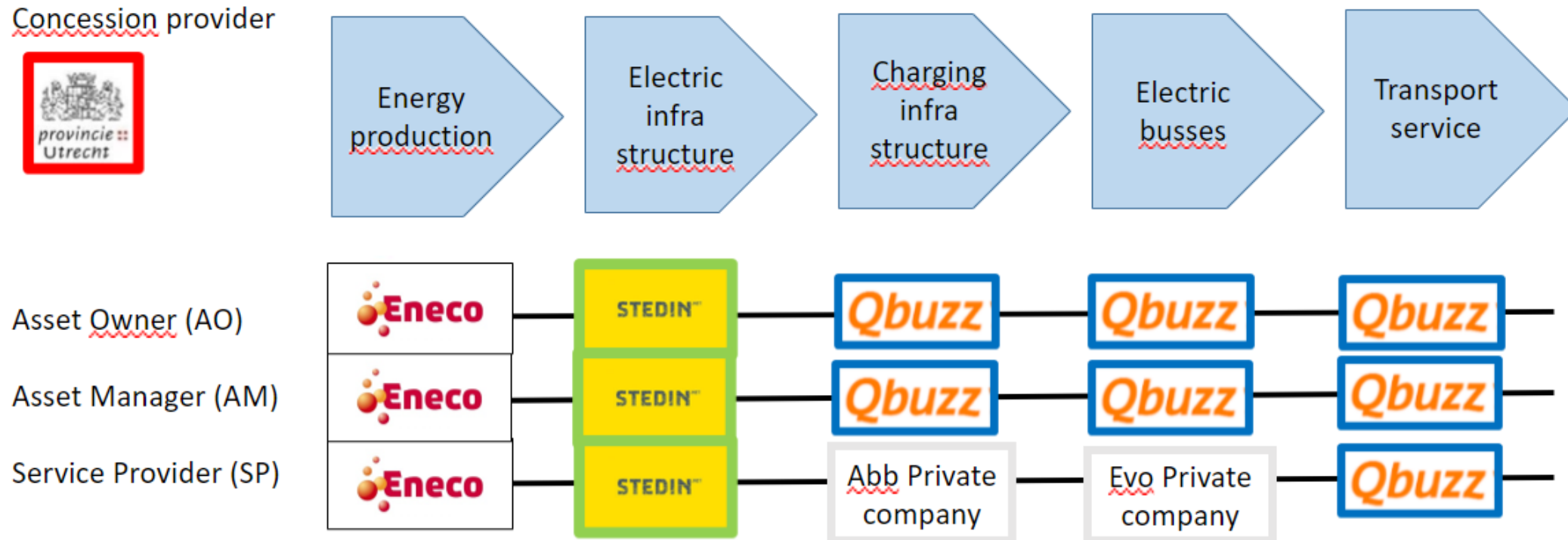



Practice Charging Infrastructure & Depots

- Essentials for e-buses operations
- More depot charging; due larger range battery-buses
- Big-scale e-charging on depots is challenging:
 - E-network capacity/Energy storage/peak shaving
 - Safety
 - Space & Costs

 Survey-type of tool easy to use for different stakeholders





What (other) difficulties in e-bus practices eBussed found?

- **Technical limitations:**
 - Early technic & innovations
 - Operational ranges/longer buses
 - Weather conditions: airco&heating
 - More & complex Systemintegration
- **Longer Implementation-phases**
 - Realistic time schedule
 - Testing&Training&Acceptance
- **Acceptance & commitment new innovations**
 - Politicans and citizens
 - PT-company: management & operational staff





What recommendations can eBussed give to other regions for e-bustransition?

WHY:

- **E-bus technology has grown up; so use it:**
 - The busmarket offers now plenty “off the shelf” e-bustypes
 - No/less addition costs in total costs of ownership
- **E-buses gives clear benefits to your region:**
 - Zero emissions/ cleaner and quieter environment
 - Higher appreciation by passengers
 - Happier busdrivers

HOW:

- **Make a strategic plan:**
 - Set a clear target (national/regional/local)
 - Seek commitment with partners (e.g. agreement)
 - Global time-schedule: first small & easy steps, learn and scale up
 - Involve total e-bus system: Energy-charging infrastructure- buses - operations
- **Look for opportunity's :**
 - New fundings
 - Climate/Energy-transition
- **Lear from others**
 - National partners and institutions (public and/or private)
 - International projects, e.g. www.interregeurope.eu/ebussed/



eBussed
Interreg Europe



European Union
European Regional
Development Fund



Thank you!

Jeroen Golstein
jeroen.golstein@provincie-Utrecht.nl
www.interregeurope.eu/ebussed/

More information

- on e-Bussed website:
 - Ebussed Library-Status Quo Fact Sheets
 - Good Practices
 - Thematic articles
 - News



**Interreg
Europe**



European Union | European Regional Development Fund